

Base Espacenet

Módulo 3

Pesquisadores em PI
DIESP / CEPIT / DIRPA

Rio de Janeiro, outubro de 2022

Sumário

Introdução

Campos de busca

Busca Rápida

Busca Avançada

My Espacenet

Outros recursos:

- Tradução;
- Compartilhar, imprimir e baixar documentos
- Uso de filtros;
- Gráficos;
- Buscar a Classificação;

Help (Ajuda)

Considerações finais

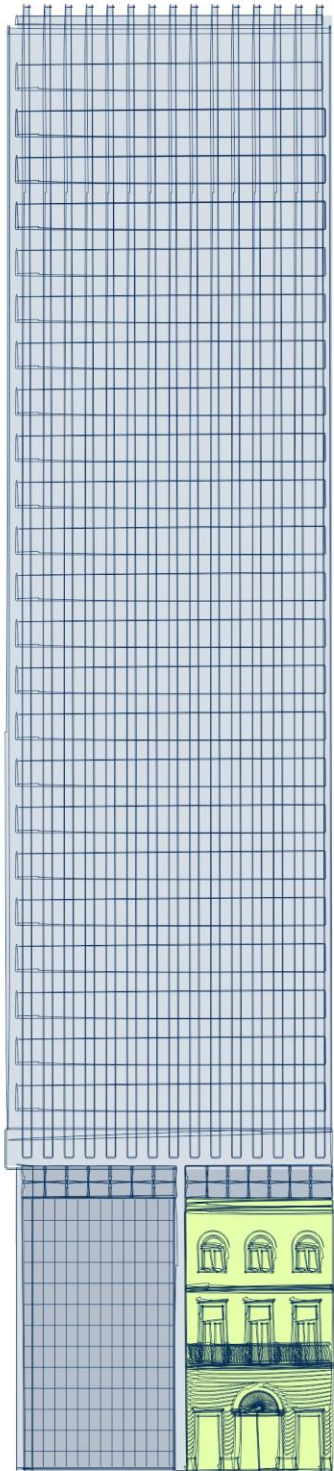

Base Espacenet

Introdução

Espacenet é a base de dados do Escritório Europeu de Patentes (EPO), que permite o **acesso gratuito** a mais de **130 milhões** de documentos de patente de escritórios de PI governamentais de **mais de 100 países**.

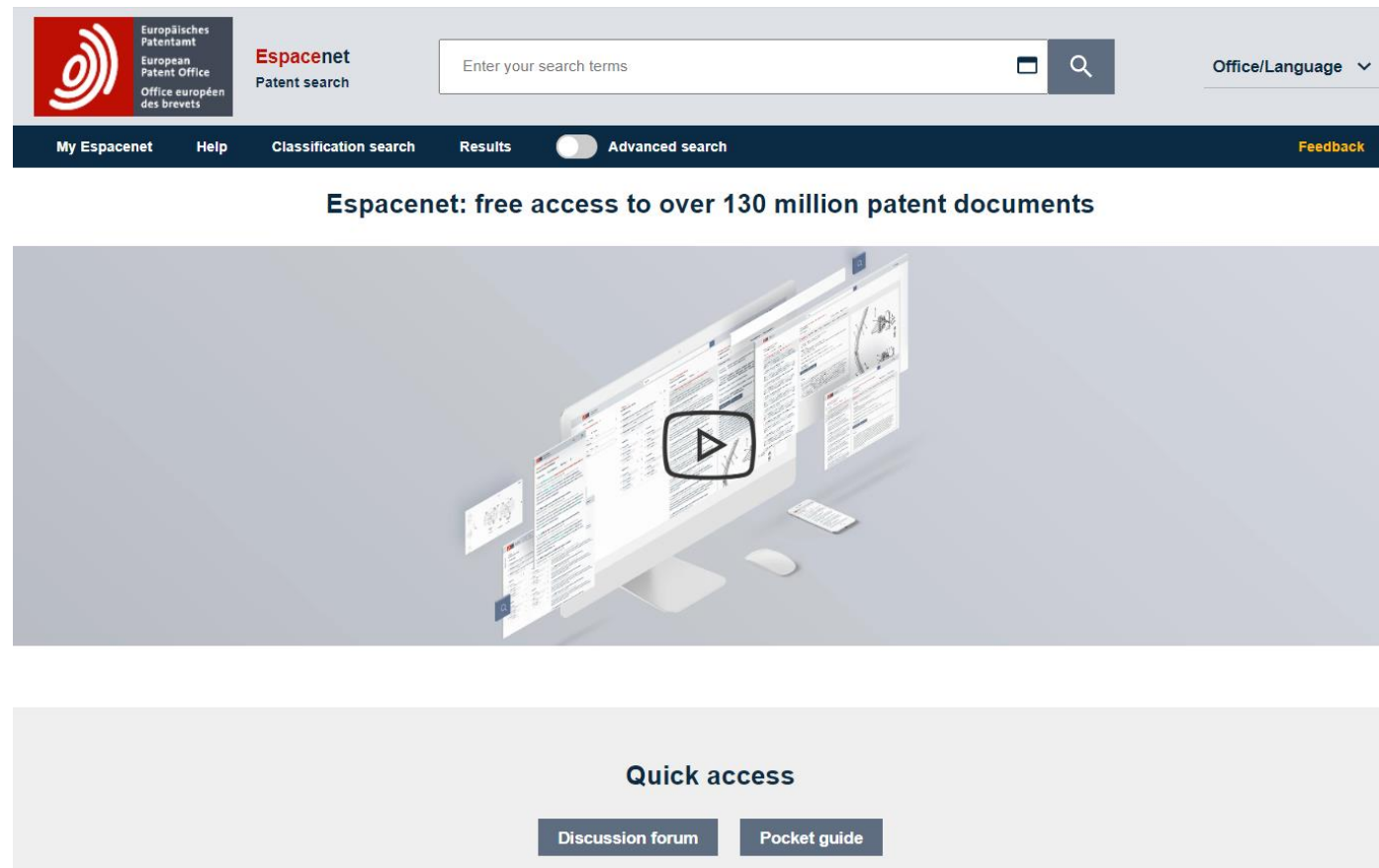

The screenshot shows the top navigation bar of the Espacenet website. On the left, there is a logo for the European Patent Office (EPO) with text in German, English, and French. Next to it is the 'Espacenet Patent search' logo. A search input field contains the placeholder text 'Enter your search terms' and has a search icon. On the right, there is a dropdown menu for 'Office/Language'. Below the search bar is a dark navigation bar with links for 'My Espacenet', 'Help', 'Classification search', 'Results', and 'Advanced search' (which is currently selected). A 'Feedback' link is also present on the far right. Below the navigation bar, a headline reads 'Espacenet: free access to over 130 million patent documents'. The main content area features a 3D rendering of a computer monitor displaying a patent document, with a play button icon overlaid on the screen. Below this, a 'Quick access' section contains two buttons: 'Discussion forum' and 'Pocket guide'.

Página inicial da base *Espacenet* (nova versão “beta” lançada em 2019)

Para acessar a base, utilizar o *link*: [Espacenet – patent search](#)

Introdução

Também está disponível a **interface de pesquisa Latipat - Espacenet** para a busca de documentos de patentes em **espanhol e português**, nos documentos de patente da América Latina e Espanha.

OBS: O Módulo 2 explica como usar a base Latipat (EPO).

LATIPAT Espacenet
Pesquisa de patentes
Um serviço prestado em cooperação com a IEP

Español Português English
Contacto
Alterar país ▼

← Espacenet Outros serviços online EPO ▼

Pesquisar Lista dos resultados A minha lista de patentes (0) Historial Configurações Ajuda

Pesquisa inteligente
Pesquisa Avançada
Pesquisa por Classificação

Ajuda rápida

- Quantos termos posso introduzir por cada campo?
- Posso efectuar uma pesquisa usando uma combinação de palavras?
- Como introduzo os termos a partir da designação ou das reivindicações?
- Posso usar truncatura ou símbolos genéricos?
- Como introduzo números de publicação, pedido, prioridade ou de referência NPL?
- Como introduzo o nome das pessoas ou das organizações?
- Qual é a diferença entre a CIP e a CPC?
- Que formatos posso utilizar para a data de publicação?
- Como introduzo um intervalo de datas para pesquisa de uma data de publicação?
- Posso salvar a minha pesquisa?

Links relacionados +

Pesquisa Avançada

Seleccione a colección em que pretende pesquisar:

Worldwide - Coleção completa dos pedidos de patente publicados em mais de 90 países

Digite os seus termos de pesquisa - CTRL-ENTER expande o campo onde você está

Introduza palavras-chave

Palavra(s)-chave no título:

Palavra(s)-chave no título ou resumo:

Digite os números com ou sem código de país

Número de publicação:

Número de pedido:

Número de prioridade:

Entre uma ou mais datas ou intervalos de datas

Data de publicação:

Digite o nome de uma ou mais pessoas / organizações

Requerente(s):

Inventor(es):

Entre um ou mais símbolos de classificação

CPC

IPC

Limpar PESQUISAR

Acesso ao Latipat: <https://lp.espacenet.com/> e https://lp.espacenet.com/advancedSearch?locale=es_LP

Introdução

A nova versão da **Espacenet** permite uma **busca interativa**, por meio de campo e seleções simples.

É de **fácil visualização e interação**.

Permite a **alteração dos parâmetros nos campos de busca** de maneira **simultânea à visualização** das **figuras** dos documentos.

Permite a visualização dos resultados da busca por meio de **gráficos**.

É possível **baixar os documentos buscados**.

Permite **baixar a folha de rosto** das patentes que constam na lista de resultados da busca.

Estão acessíveis as demais funcionalidades da antiga *Espacenet*, como a **tradução de documentos** e a **busca por classificações**.

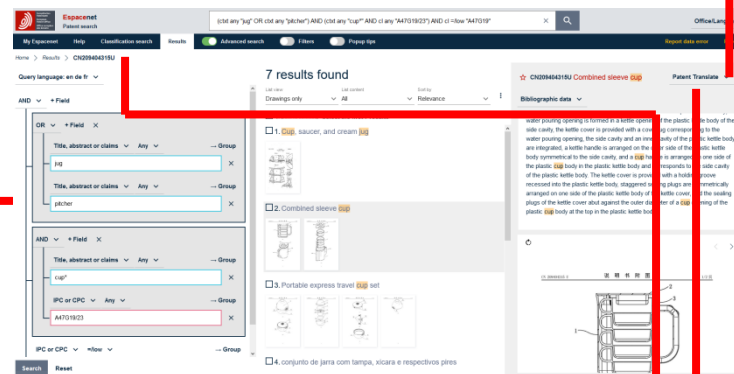

Permite o acesso a **documentos citados e citantes**.

Página inicial da *Espacenet* “beta”

Na **primeira página** são encontrados os seguintes recursos:

- **Barra de tarefas;**
- **Campo de busca;**
- **Vídeo de apresentação, e;**
- **Botões de acesso:**
 - **Fórum de discussão;**
 - **Pocket guide**

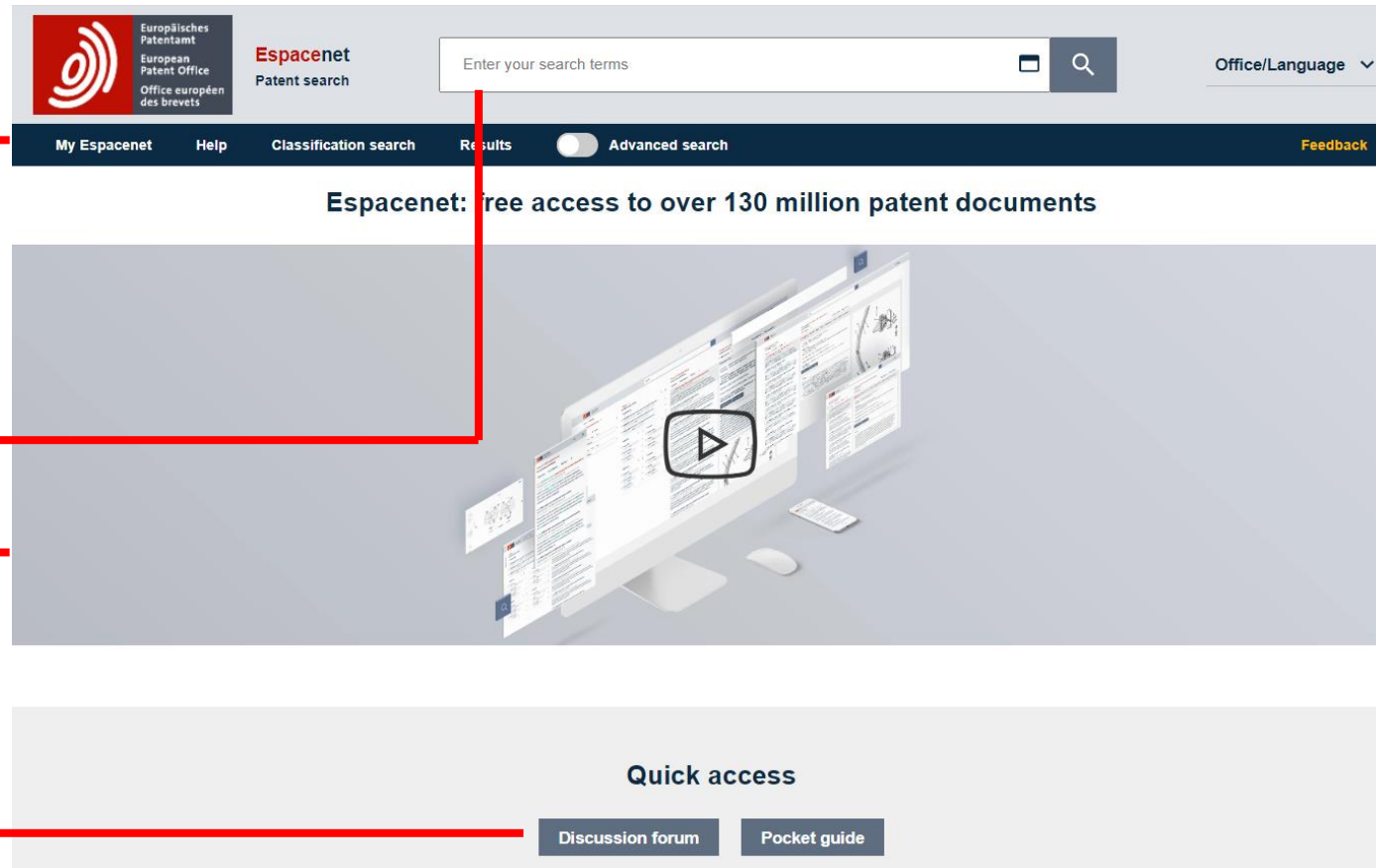

Busca Rápida: Campos de busca

No **campo de busca**, as palavras podem ser digitadas livremente, clicando na “*lupa*” para fazer a busca.

Se não houver operador entre os termos, o sistema entende como se houvesse o “**AND**”.

Podem ser utilizadas distintas informações e diferentes operadores.



Operadores e truncamentos	Truncamentos/operadores	Sintaxe ou “frase”
Documentos que apresentem simultaneamente os Conceitos.	AND	CUP JUG CUP AND JUG
Documentos que apresentem um ou outro conceito	OR	JUG OR PITCHER
RADICAL	TERM*	CUP*; JUG*
PLURAL	TERMO?	CUP?; JUG?

Para maiores informações, ver o “pocket guide” do Espacenet, no link:

[http://documents.epo.org/projects/babylon/eponet.nsf/0/8C12F50E07515DBEC12581B00050BFDA/\\$File/espacenet-pocket-guide_en.pdf](http://documents.epo.org/projects/babylon/eponet.nsf/0/8C12F50E07515DBEC12581B00050BFDA/$File/espacenet-pocket-guide_en.pdf)

Busca Rápida: Exemplo

The screenshot displays the Espacenet patent search interface. At the top, the search bar contains 'biodiesel Petrobras'. Below the search bar, the navigation menu includes 'My Espacenet', 'Help', 'Classification search', 'Results', 'Advanced search', 'Filters', and 'Popup tips'. The search results page shows 107 results found. The first result is selected, displaying the patent details for EP3305877A1, titled 'PROCESS FOR PURIFYING BIODIESEL'. The details include bibliographic data, description, claims, drawings, original document, citations, legal events, and patent family. The abstract describes a process for purifying biodiesel without using a filter aid. On the right side, a front-page drawing from EP3305877A1 is shown, illustrating a process flow with various stages and components labeled with numbers and letters (e.g., 2, 3a, 3b, 4a, 5, 8, 9).

É possível **inserir as informações da busca** no campo existente no alto da página (com ou sem os operadores booleanos). Ao clicar na **lupa**, aparecerão os **resultados da busca** no lado esquerdo. E se **selecionar um dos documentos**, ele poderá ser **visualizado no lado direito**.

Busca Avançada

A busca pode ser realizada também por meio dos campos de busca, quando ativada a “**Busca Avançada**”.

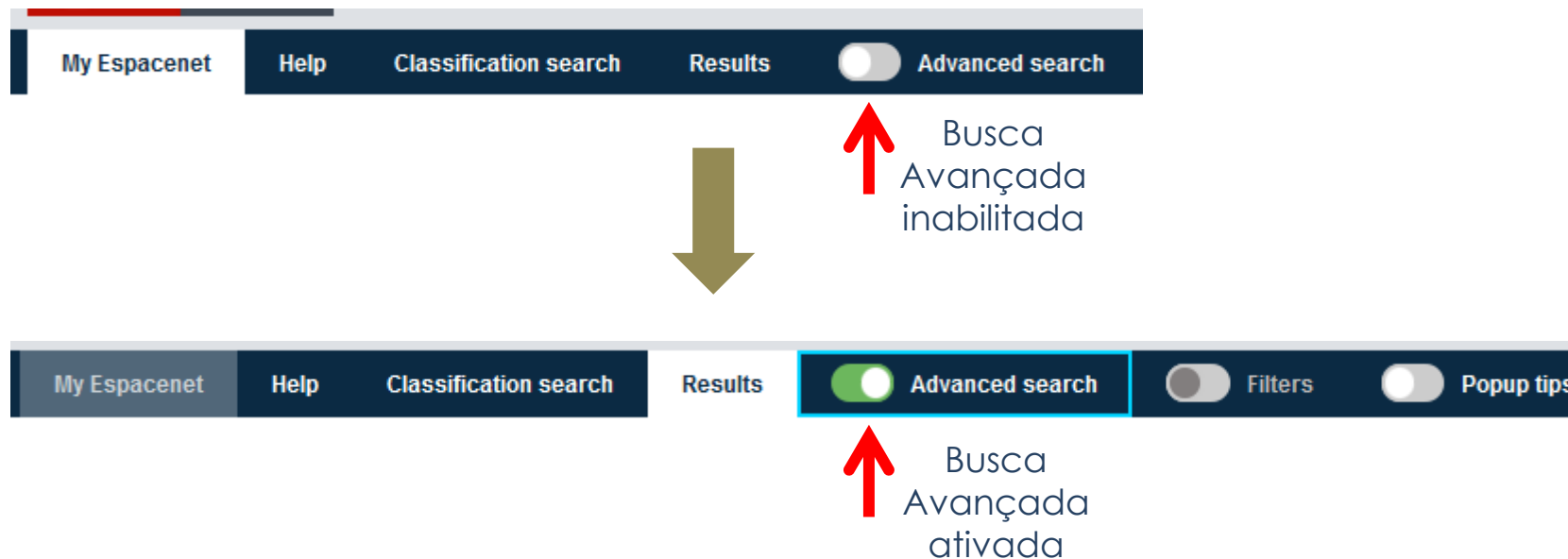

Busca Avançada

Ao ativar a “**Busca Avançada**”, aparecem na lateral da tela vários campos de busca relacionados à diversas informações, como:

- **texto nas diversas partes do documento** (termos para a busca);
- **números do documento** (publicação, prioridade, etc);
- **datas** (depósito, publicação, etc);
- **nomes** (depositante e inventor); e,
- **classificações** (IPC ou CPC).

The screenshot displays the Espacenet Patent search interface. At the top, there is a search bar with the text "Enter your search terms". Below the search bar, there are navigation links: "My Espacenet", "Help", "Classification search", "Results", "Advanced search" (which is highlighted), "Filters", and "Popup tips".

The main search area is titled "Query language: en de fr" and "AND + Field". It contains several search groups:

- AND + Field**: This group contains two search fields. The first is labeled "Title" with a dropdown menu set to "All". The second is labeled "Title or abstract" with a dropdown menu set to "All".
- OR + Field**: This group contains three search fields. The first is labeled "Publication number" with a dropdown menu set to "Any". The second is labeled "Application number" with a dropdown menu set to "Any". The third is labeled "Priority number" with a dropdown menu set to "Any".
- Publication date**: A search field with a dropdown menu set to "=".
- OR + Field**: This group contains two search fields. The first is labeled "Applicants" with a dropdown menu set to "Any". The second is labeled "Inventors" with a dropdown menu set to "Any".
- OR + Field**: This group contains two search fields. The first is labeled "CPC" with a dropdown menu set to "Any". The second is labeled "IPC" with a dropdown menu set to "Any".

At the bottom of the interface, there are "Search" and "Reset" buttons.

Busca Avançada

Home > Search

Query language: en de fr ▾

AND ▾

+ Field

The screenshot shows a search interface with a nested structure. At the top, there is a dropdown menu for 'Query language' with options 'en', 'de', and 'fr'. Below this, there is a search operator dropdown set to 'AND' and a '+ Field' button. The main search area is a grey box containing two search groups. Each group has a dropdown for the search field (e.g., 'Title', 'Title or abstract') and a dropdown for the search scope (e.g., 'All'). To the right of each group is a '→ Group' button. Below each group is a search input field with a clear 'X' button.

Pode-se selecionar o **idioma** dos documentos.

Clicar para selecionar **operadores** “AND”, “OR” ou “NOT”

É possível clicar para **adicionar (+) ou remover (x) campos de busca.**

Nos campos da “**busca avançada**”, preenche-se os dados da busca, selecionando-se os **operadores booleanos AND** e/ou **OR**, dependendo do **objetivo** e da **estratégia da busca**.

Busca Avançada

Home > Search

Query language: en de fr ▾

AND ▾ + Field

The screenshot shows a search interface with a main search box and a nested search box. The main search box has a header with "AND ▾ + Field ×" and a "Group" button. Below the header, there are two search fields. The first field is labeled "Title" and has a dropdown menu set to "All". The second field is labeled "Title or abstract" and also has a dropdown menu set to "All". Both fields have a "Group" button to their right. A red arrow points from the text on the right to the "Group" button of the first field. Another red arrow points from the text on the right to the "Group" button of the second field.

Campos para **buscar os termos** nas **partes do documento** de patente: **todos os textos; dados em campos de texto; nomes** (inventor; depositante); **data de publicação; números** (prioridade, publicação, pedido, todos os números); **classificações** (CPC, IPC); e **outro** (documentos citados).

Abre um campo para relacionar outros conceitos ao conceito que está sendo buscado.

Busca Avançada

Campos para **buscar as palavras-chave** nas **partes do documento** de patente:

The screenshot displays the advanced search interface for Espacenet. A dropdown menu is open, showing the following categories:

- 1 All
- 2 Text fields
- 3 Names
- 4 Dates
- 5 Numbers
- 6 Classifications
- 7 Other

The main search area shows the following selected categories and their sub-options:

- All (1)**
 - All text fields or names
 - Title, abstract or names
- Text fields (2)**
 - Title
 - Abstract
 - Description
 - Claims
 - Title or abstract
 - Title, abstract or claims
 - All text fields
- Names (3)**
 - Inventors
 - Applicants
 - Inventors or applicants
- Dates (4)**
 - Publication date
- Numbers (5)**
 - Priority number
 - Publication number
 - Application number
 - All numbers
- Classifications (6)**
 - IPC
 - CPC
 - CPC C-sets
 - IPC or CPC
- Other (7)**
 - Cited documents

Busca Avançada

Pode-se iniciar a “**Busca Avançada**”, adicionando-se os campos de busca.

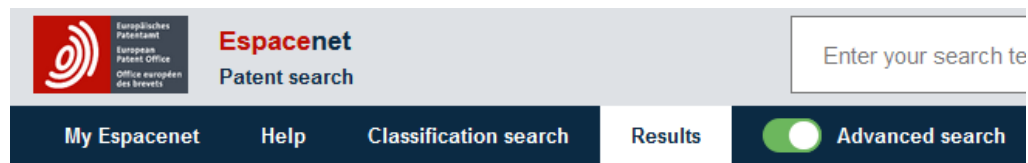

Home > Results

Query language: en de fr ▾

AND ▾ + Field



Clicar para adicionar os campos de busca.

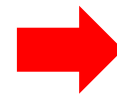

É possível alterar onde buscar o termo digitado no campo.

Busca Avançada

AND ▾ + Field

Title, abstract or claims ▾ Any ▾

Any

All

Proximity

= → Group

×

Detailed description: This screenshot shows the search interface for Espacenet. At the top, there is a dropdown menu with 'AND' and a plus sign followed by 'Field'. Below this, there are two dropdown menus: 'Title, abstract or claims' and 'Any'. To the right of these is a list of search operators: 'Any', 'All', and 'Proximity'. A red bracket groups these three options, with an arrow pointing to the text 'Operadores de distância que podem ser selecionados.' Below the operator list is an equals sign followed by '→ Group'. A search input field is shown below the dropdowns, with a red 'x' icon to its right. A red arrow points from the 'Any' operator to the search field.

Operadores de distância que podem ser selecionados.

Neste caso, foi selecionado o campo que trata do texto nas partes do pedido. Os termos são digitados no campo de busca.

AND ▾ + Field

Title, abstract or claims ▾ Proximity ▾

words away from

words away from (ordered)

appears before

in the same sentence as

in the same paragraph as

up

×

< ▾ 3 ▾ words away from ▾

Detailed description: This screenshot shows the search interface for Espacenet. At the top, there is a dropdown menu with 'AND' and a plus sign followed by 'Field'. Below this, there are two dropdown menus: 'Title, abstract or claims' and 'Proximity'. To the right of these is a list of search operators: 'words away from', 'words away from (ordered)', 'appears before', 'in the same sentence as', and 'in the same paragraph as'. A red bracket groups these five options, with an arrow pointing to the text 'No operador "proximity", podem ser selecionados: distâncias entre os termos (ordenados ou não); termos que aparecem antes; termos na mesma frase ou no mesmo parágrafo.' Below the operator list is an equals sign followed by 'up'. A search input field is shown below the dropdowns, with a red 'x' icon to its right. Below the search field, there is a dropdown menu with '<' and a plus sign followed by '3', and another dropdown menu with 'words away from'. A red arrow points from the 'Proximity' operator to the search field.

No operador "**proximity**", podem ser selecionados: **distâncias entre os termos** (ordenados ou não); **termos que aparecem antes**; **termos na mesma frase** ou **no mesmo parágrafo**.

Busca Avançada

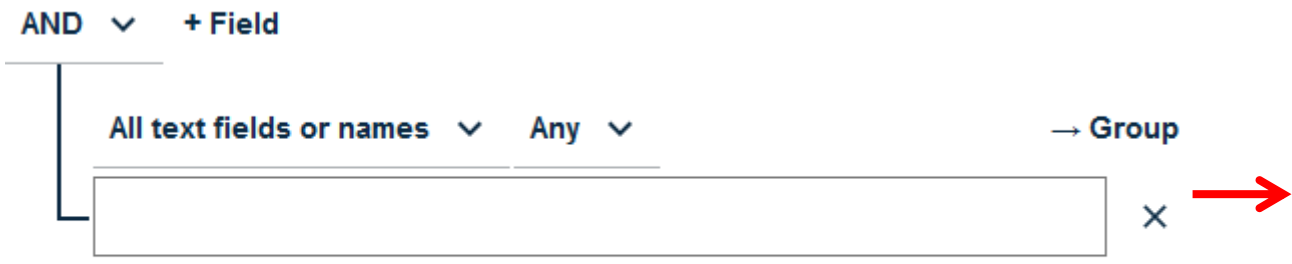

Campo de busca para **qualquer texto ou nomes** em qualquer parte do documento.

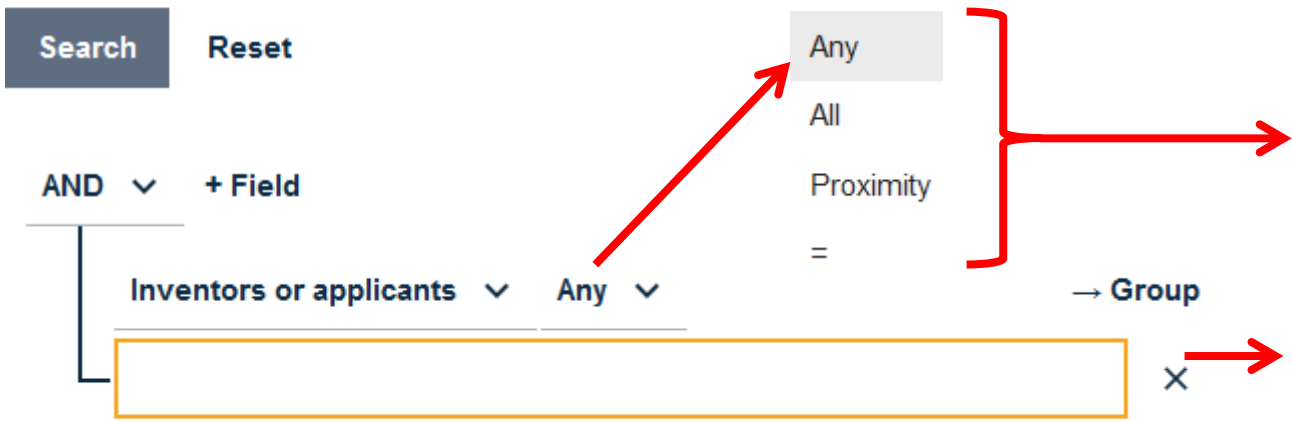

Seleção de operadores de **proximidade**, sendo possível selecionar a **quantidade de palavras entre os termos da busca** (“*proximity*”).

Campo de busca por **nomes**, podendo-se selecionar **depositante ou inventor**, ou os dois **simultaneamente**.



Busca Avançada

AND ▾ + Field

Publication date ▾ Within ▾

Within
>
>=
<
<=
=

→ Group

×

Seleção dos **limites de tempo**: entre datas; maior que; maior ou igual; menor que; menor ou igual; data igual.

Campo de busca por **data de publicação**.

Search Reset

AND ▾ + Field

All numbers ▾ Any ▾

→ Group

×

Campo de busca por **números** relacionados às patentes: **número da prioridade**; **número da publicação**; **número do pedido**; e **todos os números**.

Search Reset

Busca Avançada

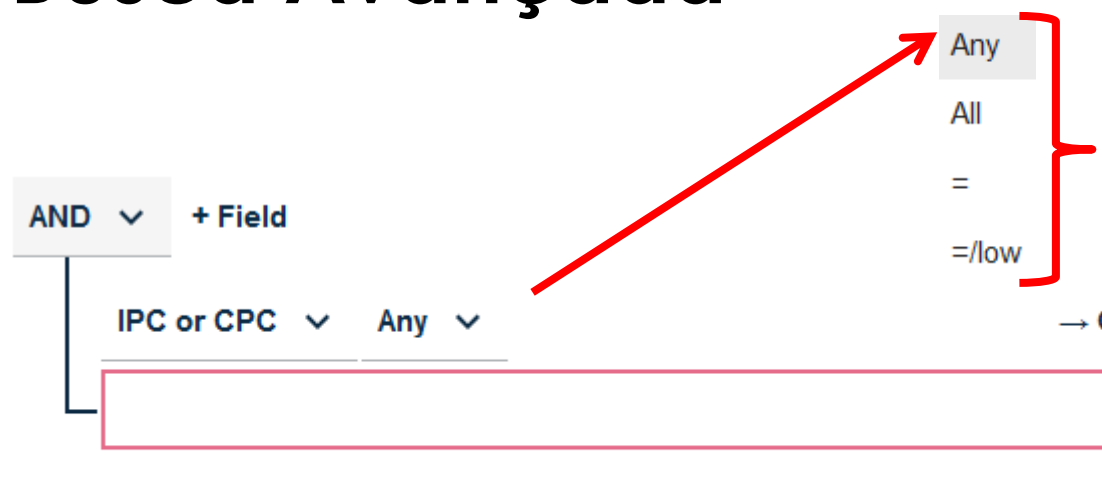

AND ▾ + Field

IPC or CPC ▾ Any ▾

Any
All
=
=/low

→ Group

×

Seleção dos **limites da classificação**, sendo importante para **definir o alcance no campo técnico pesquisado**.

Campo de busca por classificação

Search **Reset**



AND ▾ + Field

Cited documents ▾ Any ▾

→ Group

×

Campo de busca referente aos **documentos citados**.

Search **Reset**

Busca Avançada: Operadores Booleanos

Query language: en de fr ▾

AND ▾ + Field

Title, abstract or claims ▾ Any ▾ → Group

Search Reset

AND ▾ + Field

OR ▾ + Field ×

Title, abstract or claims ▾ Proximity ▾ → Group

< ▾ 3 ▾ words away from ▾

Title, abstract or claims ▾ Proximity ▾ → Group

< ▾ 3 ▾ words away from ▾

Os campos de busca também podem ser relacionados através dos operadores booleanos "AND", "OR", "NOT".

Busca Avançada: *Inventor / Depositante*

Query language: en de fr ▾

AND ▾ + Field

Inventors or applicants ▾ Any ▾ → Group

Nely Cristina Braidotti ×

Query language: en de fr ▾

AND ▾ + Field

Inventors or applicants ▾ Proximity ▾ → Group

Nely ×

< ▾ 3 ▾ words away from ▾

Braidotti ×

7 364 results found

List view List content
Text only ▾ All

(0 patents selected) Select the first 20

1. **frasco para o acondicioname**
BRMU8902144U2 (Y1) • 2011-03-
Earliest priority: 2009-06-30 • Earliest p

129 results found

List view List content
Text only ▾ All

(0 patents selected) Select the first 20

1. **HAMBURGER MOLD**
US10682017B2 (A1) • 2020-06-16
Earliest priority: 2016-06-17 • Earliest p
A hamburger mold is provided, which refer
preparation of handmade hamburgers, be
several formats, in relation to its thickness

Realizar a busca colocando **apenas** os **nomes e sobrenomes do inventor/ depositante** amplia o número de documentos localizados na busca, **abrangendo outros inventores/ depositantes**.

Já com a busca utilizando **operadores booleanos e de proximidade, refina-se o resultado**, havendo maior certeza de que se trata do inventor/ depositante do pedido buscado.

Também pode ser realizada a **busca pelos nomes do inventor ou depositante**.

Busca Avançada: *Inventor / Depositante*

Home > Results

Query language: en de fr ▾

AND ▾ + Field

Inventors or applicants ▾ Proximity ▾ → Group

Nely

Braidotti

Title, abstract or claims ▾ Any ▾ → Group

CUP*

4 results found

List view

List content

Sort by

Text only ▾

All ▾

Relevance ▾

(0 patents selected) **Select the first 4 results**

1. conjunto de jarra com tampa, xícara e respectivos pires
BRMU8700249U (Y1) • 2008-09-30 • BRAIDOTTI NELY CRISTINA [BR]

Earliest priority: 2007-02-12 • Earliest publication: 2008-09-30

CONJUNTO DE JARRA COM TAMPA, XICARAS E RESPECTIVOS PIRES Estando a jarra compreendida por um recipiente (1) que tem na frente, em quase toda a sua extensão, uma região avançada semicircular (2) que define o bico da jarra e opostamente tendo

2. disposição introduzida em garrafa para lancheira

BRMU8702422U2 (Y1) • 2009-06-09 • BRAIDOTTI NELY CRISTINA [BR]

Earliest priority: 2007-10-19 • Earliest publication: 2009-06-09

Combinando-se a busca por nome (inventor/ depositante) com uma das **palavras-chave**, **refina-se** ainda mais o **resultado**, podendo-se observar outros pedidos do depositante **equivalentes à inovação** do pedido buscado.

Busca Avançada: *Busca por palavras-chave*

The screenshot displays the Espacenet patent search interface. At the top, the search query is entered in a search bar: `(ctxt any "jug" OR ctxt any "pitcher") AND ctxt=("cup*" prox/distance<3 "saucer*")`. Below the search bar, the interface is divided into three main sections:

- Search Fields (1):** The search query is broken down into three groups. The first group contains "jug" and "pitcher" connected by an OR operator. The second group contains "cup*" and "saucer*" connected by an AND operator, with a proximity filter set to "3 words away from".
- Search Results (2):** The results section shows "12 results found". The first three results are listed:
 - 1. **Cup, saucer, and cream jug** (US2583951A • 1952-01-29 • No applicant available. Earliest priority: 1946-10-11 • Earliest publication: 1952-01-29. No abstract available).
 - 2. **Cup, saucer, and cream jug combination** (US2618943A • 1952-11-25 • No applicant available. Earliest priority: 1952-01-31 • Earliest publication: 1952-11-25. No abstract available).
 - 3. **A tea-set stand** (GB850093A • 1960-09-28 • B C JEWERS LTD. Earliest priority: 1957-11-22 • Earliest publication: 1960-09-28. 850,093. Stands. JEWERS Ltd., B. C. Feb. 23, 1959 [Nov. 22. 1957], No. 32882/57. Class 52(3) A stand for the display, carrying or storage of a tea-set has a plate ring 10. saucer ring 11 and a cup hook and handle assembly 13 spaced apart vertically and held in position by
- Selected Document (3):** The fourth result, "Central armrest box for car" (CN107264420A • 2017-10-20 • JIANGSU FARID SPECIAL AUTOMOBI...), is highlighted with a blue bar, indicating it is the selected document.

A tela se divide em três áreas principais: (1) **campos de busca**; (2) **lista de documentos encontrados**; e (3) **documento selecionado**

Busca Avançada desabilitada

Sintaxe de busca com operadores e códigos dos campos selecionados

The screenshot displays the Espacenet patent search interface. At the top, a search bar contains the query: (ctxt any "jug" OR ctxt any "pitcher") AND ctxt=("cup*" prox/distance<3 "saucer*"). Below the search bar, there are navigation tabs: My Espacenet, Help, Classification search, Results, Advanced search, Filters, and Popup tips. The 'Advanced search' tab is selected. The search results page shows 12 results found. The first result is selected and highlighted with a red circle. A red arrow points from the search bar to the selected result. The selected result is a patent document titled 'Cup, saucer, and cream jug' (US2583951A) by G. Kliegel, filed on Oct. 11, 1946. The document includes a title page with the date 'Jan. 29, 1952' and the number '2,583,951'. Below the title page are two figures: FIG. 1, a perspective view of a cup with a saucer and a cream jug, and FIG. 2, a side view of the cup. The figures are labeled with numbers 1 through 8.

Ao fazer a busca com a opção “**Busca avançada**” desabilitada, a tela fica dividida em dois espaços, um destinado à **lista de documentos** encontrados na busca (1), e outro com o **documento selecionado** (2).

Busca Avançada: *Sintaxe de busca*

The screenshot shows the Espacenet patent search interface. At the top, the search query is entered in the search bar: `(ctxt any "jug" OR ctxt any "pitcher") AND ctxt=("cup*" prox/distan`. Below the search bar, there are navigation tabs: "My Espacenet", "Help", "Classification search", "Results", "Advanced search" (which is selected), "Filters", and "Popup tips".

Under the "Results" tab, the query language is set to "en de fr". The search criteria are displayed as follows:

- AND + Field
- OR + Field X
 - Title, abstract or claims Any → Group
 - jug X
 - Title, abstract or claims Any → Group
 - pitcher X
 - Title, abstract or claims Proximity → Group
 - cup* X
 - < 3 words away from
 - saucer* X

At the bottom, there are "Search" and "Reset" buttons.

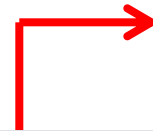

No **campo de busca**, a **"frase"** ou **"sintaxe"** é formada **automaticamente**, figurando parte da estratégia de busca.

12 results found

The results page shows 12 results found. The view is set to "Text only" and "List content" is set to "All". There are 0 patents selected. The first 12 results are displayed:

1. Cup, saucer, and cream jug
US2583951A • 1952-01-29 • No applic
Earliest priority: 1946-10-11 • Earliest public
No abstract available
2. Cup, saucer, and cream jug com
US2618943A • 1952-11-25 • No applic
Earliest priority: 1952-01-31 • Earliest public
No abstract available
3. A tea-set stand
GB850093A • 1960-09-28 • B C JEW
Earliest priority: 1957-11-22 • Earliest public
850,093. Stands. JEWERS Ltd., B. C. Feb. 23,
52(3) A stand for the display, carrying or stora
11 and a cup hook and handle assembly 13 sp
4. Central armrest box for car
CN107264420A • 2017-10-20 • JIANG
Earliest priority: 2017-05-31 • Earliest public

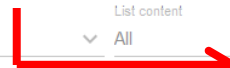

É exibido o **número de documentos recuperados** com a busca.

Campos de texto, onde são preenchidos os termos da busca.

Para fins de exemplo, no primeiro campo, os termos estão agrupados com o operador **"OR"** por serem sinônimos.

Busca Avançada: *Truncamento de palavras*

Home > Results

Query language: en de fr

AND + Field

OR + Field X

- Title, abstract or claims Any Group
jug X
- Title, abstract or claims Any Group
pitcher X
- Title, abstract or claims Any Group
cup*

Search Reset

1 369 results found

Text only All Relevance

(0 patents selected) Select the first 20 results

1. **PITCHER CUP**
JP2003275084A • 2003-09-30 • YOKOYAMA KUNIO
Earliest priority: 2002-03-20 • Earliest publication: 2003-09-30
...PROBLEM TO BE SOLVED: To provide a pitcher cup utilizing charcoal and ores to remove the impurities in water... the pitcher cup is made of earthenware. The water therein is removed of the impurities and can be comfortably drunk ...

2. **JUG FOR BEVERAGES AND BEVERAGE PRODUCING MACHIN...**
RU2015146919A (C2) • 2017-05-11 • КОНИНКЛЕЙКЕ ФИЛИПС Н.В.
Earliest priority: 2013-04-02 • Earliest publication: 2014-10-09
...FIELD: personal and household items.SUBSTANCE: present jug (11) comprises jug body (15) and beverage frothing device (13) arranged on the jug. Beverage frothing device comprises steam inlet (23, 25, 27), beverage inlet (35, 35C), and frothed beverage outlet

3. **Pitcher perfect (Machine-translation by Google Translate, not legall...**
ES1011911U (Y) • 1990-06-01 • G & D REGALOS Y DECORACION, S.A.
Earliest priority: 1989-11-02 • Earliest publication: 1990-06-01
...Pitcher improved which, being constituted by a body of any shape and can have cup-shaped, cup, etc., which is... pitcher va soldier a thread screw in a supplementary hole provided on a nut (6) welded on a surface concava determining the top of base or base for

4. **No title available**
JPS55107076U • 1980-07-26 • No applicant available
Earliest priority: 1979-01-22 • Earliest publication: 1980-07-26

Neste caso, a utilização de apenas um termo com truncamento ampliou o número de documentos de 12 para 1.369 documentos.

Os **parâmetros do campo da busca** podem ser **alterados** com o objetivo de **ampliar ou refinar a busca**.

Busca avançada: Classificação de patentes

Home > Results

Query language: en de fr ▾

AND ▾ + Field

OR ▾ + Field ×

Title, abstract or claims ▾ Any ▾ → Group

jug ×

Title, abstract or claims ▾ Any ▾ → Group

pitcher ×

Title, abstract or claims ▾ Any ▾ → Group

cup* ×

IPC or CPC ▾ =/low ▾ → Group

A47G ×

254 results found

Text only ▾ All ▾ Sort by Relevance ▾

(0 patents selected) Select the first 20 results

1. **PITCHER CUP**
JP2003275084A • 2003-09-30 • YOKOYAMA KUNIO
Earliest priority: 2002-03-20 • Earliest publication: 2003-09-30
...PROBLEM TO BE SOLVED: To provide a **pitcher cup** utilizing charcoal and ores to remove the impurities in water... the **pitcher cup** is made of earthenware. The water therein is removed of the impurities and can be comfortably drunk ...

2. **No title available**
JPS55107076U • 1980-07-26 • No applicant available
Earliest priority: 1979-01-22 • Earliest publication: 1980-07-26
No abstract available

3. **No title available**
JPS5520946U • 1980-02-09 • No applicant available
Earliest priority: 1978-07-28 • Earliest publication: 1980-02-09
No abstract available

4. **Portable water filter -pitcher that crosses**
CN205568537U • 2016-09-14 • ZHU HOULIN
Earliest priority: 2016-01-22 • Earliest publication: 2016-09-14
The utility model discloses a portable water filter **pitcher** that crosses, including the kettle body, a water storage chamber and...

5. **Jug with sugar bowl, coffee pot and cups**
US4266684A • 1981-05-12 • MACCISE YAMIL A

Search Reset

A utilização de **símbolos da classificação** refinou o resultado que era de 1.369 para 254 documentos.

Busca Avançada: Classificação de patentes

Query language: en de fr ▾

AND ▾ + Field

OR ▾ + Field ×

- Title, abstract or claims ▾ Any ▾ → Group
- jug ×
- Title, abstract or claims ▾ Any ▾ → Group
- pitcher ×

AND ▾ + Field ×

- Title, abstract or claims ▾ Any ▾ → Group
- cup* ×
- IPC or CPC ▾ Any ▾ → Group
- A47G19/23 ×

Search Reset

7 results found

Drawings only ▾ All ▾ Sort by Relevance ▾

(0 patents selected) Select the first 7 results

- 3. Combined sleeve cup
- 4. Accommodation and storage of crockery
- 5. conjunto de jarra com tampa, xicara e respectivos pires

No image found

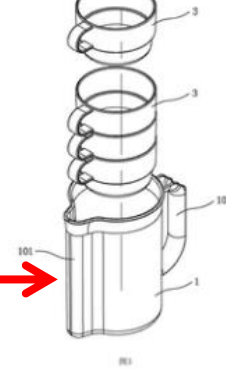

Documento encontrado na busca: CN209404315U

Relacionando-se o conceito “ser empilhável” (class. **A47G19/23**) ao termo “xícara” (cup*), refina-se ainda mais a busca.

Busca avançada: *Exibição dos resultados*

12 results found

List view: Text only (dropdown)
List content: All (dropdown)
Sort by: Relevance (dropdown)

(0 patents selected) **Select the first 12 results**

1. **Cup, saucer, and cream jug**
US2583951A • 1952-01-29 • No applicant available
Earliest priority: 1946-10-11 • Earliest publication: 1952-01-29
No abstract available

2. **Cup, saucer, and cream jug combination**
US2618943A • 1952-11-25 • No applicant available
Earliest priority: 1952-01-31 • Earliest publication: 1952-11-25
No abstract available

3. **A tea-set stand**
GB850093A • 1960-09-28 • B C JEWERS LTD
Earliest priority: 1957-11-22 • Earliest publication: 1960-09-28
850,093. Stands. JEWERS Ltd., B. C. Feb. 23, 1959 [Nov. 22, 1957], No. 32882/57. Class 52(3) A stand for the display, carrying or storage of a tea-set has a plate ring 10. saucer ring 11 and a cup hook and handle assembly 13 spaced apart vertically and held in position by

4. **Central armrest box for car**
CN107264420A • 2017-10-20 • JIANGSU FARID SPECIAL AUTOMOBILI...
Earliest priority: 2017-05-31 • Earliest publication: 2017-10-20
... expansion hinge, two **cup saucers**, a mobile phone slot, hinges, a thermal **jug**, a heating device and a control switch. **Cup saucers** are installed on the right side of the support box

Lista de documentos exibindo apenas o texto.

A seção destinada à **lista de documentos encontrados na busca** pode ser exibida de quatro maneiras:

- **Apenas texto;**
- **Texto e miniatura;**
- **Lista compacta (sem abstract), e;**
- **Apenas desenhos.**

Pode ser selecionada a **ordem de exibição** dos documentos (**relevância**):

- Ordem (crescente/ decrescente) **data da prioridade;**
- Ordem (crescente/ decrescente) **data de publicação.**

Busca Avançada: *Exibição dos resultados*

Formas de **exibição da lista de documentos** encontrados na busca:

12 results found

List view: Text and thumbnails | List content: All | Sort by: Relevance

(0 patents selected) Select the first 12 results

- 1. Cup, saucer, and cream jug
US2583951A • 1952-01-29 • No applicant available
Earliest priority: 1946-10-11 • Earliest publication: 1952-01-29
No abstract available
- 2. Cup, saucer, and cream jug combination
US2618943A • 1952-11-25 • No applicant available
Earliest priority: 1952-01-31 • Earliest publication: 1952-11-25
No abstract available

Lista e miniatura

12 results found

List view: Compact list | List content: All | Sort by: Relevance

(0 patents selected) Select the first 12 results

- 1. Cup, saucer, and cream jug
US2583951A • 1952-01-29 • No applicant available
Earliest priority: 1946-10-11 • Earliest publication: 1952-01-29
- 2. Cup, saucer, and cream jug combination
US2618943A • 1952-11-25 • No applicant available
Earliest priority: 1952-01-31 • Earliest publication: 1952-11-25
- 3. A tea-set stand
GB850093A • 1960-09-28 • B C JEWERS LTD
Earliest priority: 1957-11-22 • Earliest publication: 1960-09-28

Lista compacta

12 results found

List view: Drawings only | List content: All | Sort by: Relevance

(0 patents selected) Select the first 12 results

- 1. Cup, saucer, and cream jug
- 2. Cup, saucer, and cream jug combination

Apenas desenhos

Busca Avançada: o que fazer com os resultados

12 results found

List view Text only List content All Sort by Relevance

(0 patents selected) **Select the first 12 results**

1. **Cup, saucer, and cream jug**

US2583951A • 1952-01-29 • No applicant available

Earliest priority: 1946-10-11 • Earliest publication: 1952-01-29

No abstract available

2. **Cup, saucer, and cream jug combination**

US2618943A • 1952-11-25 • No applicant available

Earliest priority: 1952-01-31 • Earliest publication: 1952-11-25

No abstract available

3. **A tea-set stand**

GB850093A • 1960-09-28 • B C JEWERS LTD

Earliest priority: 1957-11-22 • Earliest publication: 1960-09-28

850,093. Stands. JEWERS Ltd., B. C. Feb. 23, 1959 [Nov. 22, 1957], No. 32882/57. Class 52(3) A stand for the display, carrying or storage of a tea-set has a plate ring 10. saucer ring 11 and a cup hook and handle assembly 13 spaced apart vertically and held in position by

4. **Central armrest box for car**

CN107264420A • 2017-10-20 • JIANGSU FARID SPECIAL AUTOMOBILI...

Earliest priority: 2017-05-31 • Earliest publication: 2017-10-20

... expansion hinge, two **cup saucers**, a mobile phone slot, hinges, a thermal **jug**, a heating device and a control switch. **Chairs** are installed on the right side of the seat and the

Lista de documentos exibindo apenas o texto.

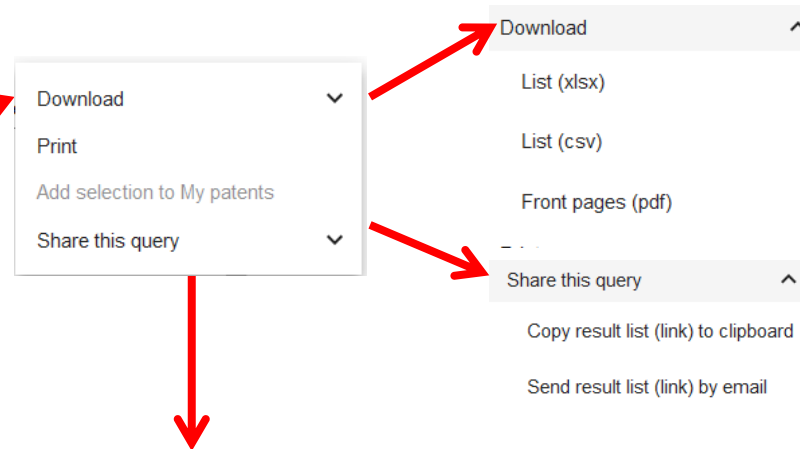

Por meio deste menu pode-se:

- **Baixar a lista** de documentos;
- **Baixar as folhas de rosto dos pedidos** onde, em geral, estão presentes as **informações bibliográficas** do pedido, podendo conter figura que representa o objeto;
- **Imprimir** a lista, e;
- **Compartilhar a estratégia**, copiando e colando o link ou enviando por e-mail.

Busca Avançada: Seleção do documento

The screenshot displays the Espacenet patent search interface. At the top, the search query is "(cbxt any "jug" OR cbxt any "pitcher") AND cbxt= ("cup*" prox/distance<3 "saucer*")". The search results show 12 results found, with the first three results highlighted. The first result is US2583951A, titled "Cup, saucer, and cream jug". The second result is US2618943A, titled "Cup, saucer, and cream jug combination". The third result is GB850093A, titled "A tea-set stand".

On the right side, the detailed view of the selected document US2583951A is shown. The document title is "Cup, saucer, and cream jug". The inventor is GEORGE KLIEGEL. The classifications are IPC A47G19/23; CPC A47G19/04 (EP); A47G19/2283 (EP); A47G19/23 (EP); Y10S215/07 (EP). The priorities are US70264646A-1946-10-11, Application US70264646A-1946-10-11, and Publication US2583951A-1952-01-29. The document is published as "Cup, saucer, and cream jug". The abstract states: "No abstract found. Please consult other publications of this patent family in "Available in", if displayed above."

Red arrows indicate the flow of information from the search results to the detailed view. The first arrow points from the first result in the list to the detailed view. The second arrow points from the second result in the list to the detailed view. The third arrow points from the third result in the list to the detailed view. The fourth arrow points from the search criteria in the left sidebar to the detailed view.

Barras laterais possibilitam o ajuste do campo de visualização da lista e do documento.

Ao selecionar um documento da lista, ele é exibido na terceira parte da tela.

Busca Avançada: Folha de rosto do documento



Espacenet search result – front page selection - 202007071312

12 results found for (ctxt any "jug" OR ctxt any "pitcher") AND ctxt=("cup*" prox/distance<3 "saucer")
Results 1 to 12 displayed
Query language: en / de / fr

Cabeçalho da lista com as folhas de rosto.

(19)中华人民共和国国家知识产权局



(12)发明专利申请



(10)申请公布号 CN 107264420 A
(43)申请公布日 2017.10.20

(21)申请号 201710396471.2

(22)申请日 2017.05.31

(71)申请人 江苏法瑞德专用汽车有限公司
地址 211200 江苏省南京市溧水区东屏镇
朝阳路39号

(72)发明人 陆松 韩加泉

(74)专利代理机构 南京苏高专利商标事务所
(普通合伙) 32204

代理人 成立珍

(51)Int. Cl.

B60R 7/04(2006.01)

B60N 3/10(2006.01)

权利要求书1页 说明书2页 附图1页

(54)发明名称

一种车用中央扶手盒

(57)摘要

本发明公开了一种车用中央扶手盒,包括扶手盒主体、伸缩铰链、杯托、手机槽、合页、热水壶、加热装置和控制开关,在扶手盒主体的右侧铜鼓伸缩铰链安装有储物格,在扶手盒的上部设有杯托,所述的杯托有两个,在扶手盒的上表面设有手机槽,手机槽安装在扶手盒的盒盖上面,手机槽的下部为热水壶,扶手盒的盒盖通过合页安装,内部安装的热水壶底部设有加热装置,在扶手盒主体的正面左侧盒体上设有控制开关,可控制热水壶的加热。本发明所述的中央扶手盒具有多个储物空间和方便车内人员引用热水问题,具有很好的实用性和便捷性,提供了一种操作方便的车用中央扶手盒。

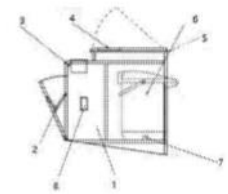

Exemplo de folha de rosto.

Busca Avançada: Exibição de partes do documento

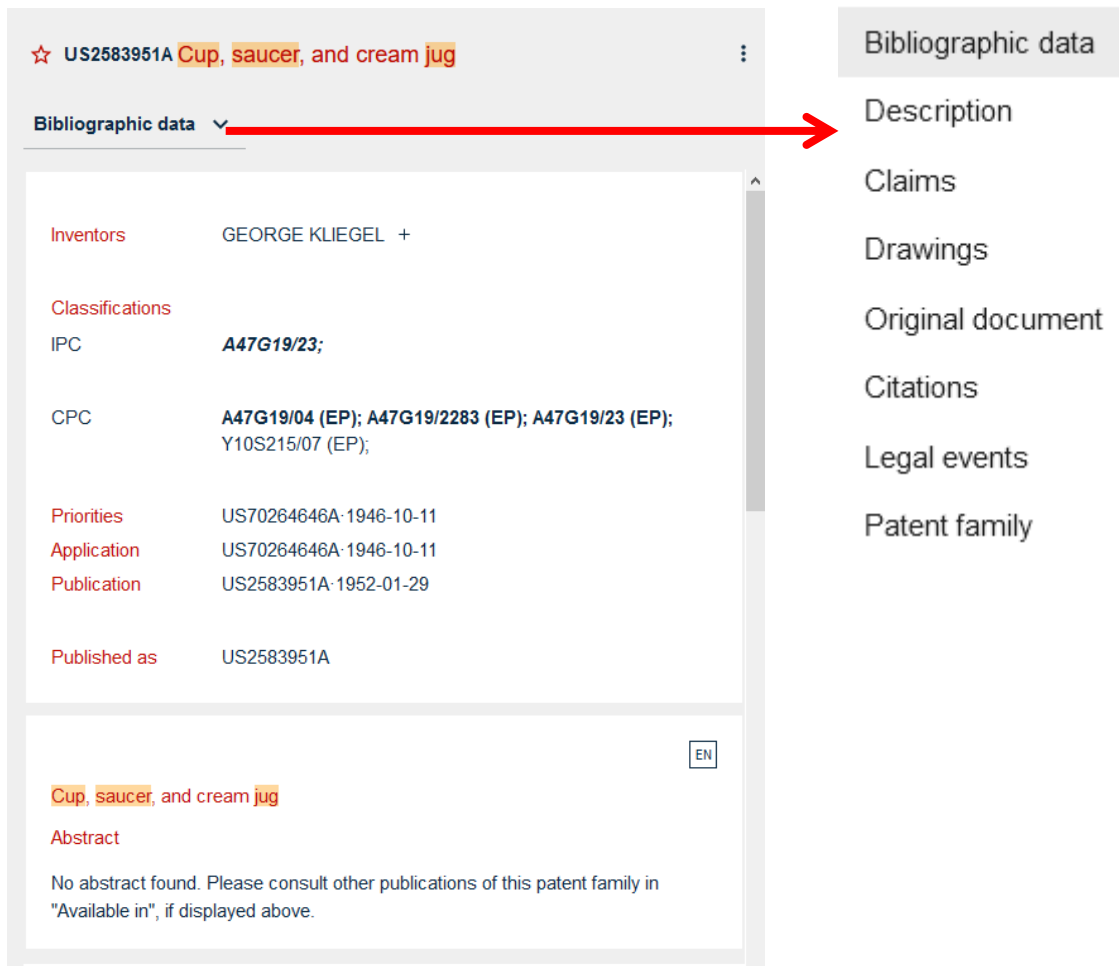

The screenshot shows the Espacenet interface for patent US2583951A. The 'Bibliographic data' menu is open, with a red arrow pointing to the 'Bibliographic data' option. The data fields are as follows:

Field	Value
Inventors	GEORGE KLIEGEL +
Classifications	
IPC	A47G19/23;
CPC	A47G19/04 (EP); A47G19/2283 (EP); A47G19/23 (EP); Y10S215/07 (EP);
Priorities	US70264646A-1946-10-11
Application	US70264646A-1946-10-11
Publication	US2583951A-1952-01-29
Published as	US2583951A

O menu principal da parte da tela destinada à exibição do documento permite a **visualização de cada parte do documento**, como os desenhos, por exemplo:

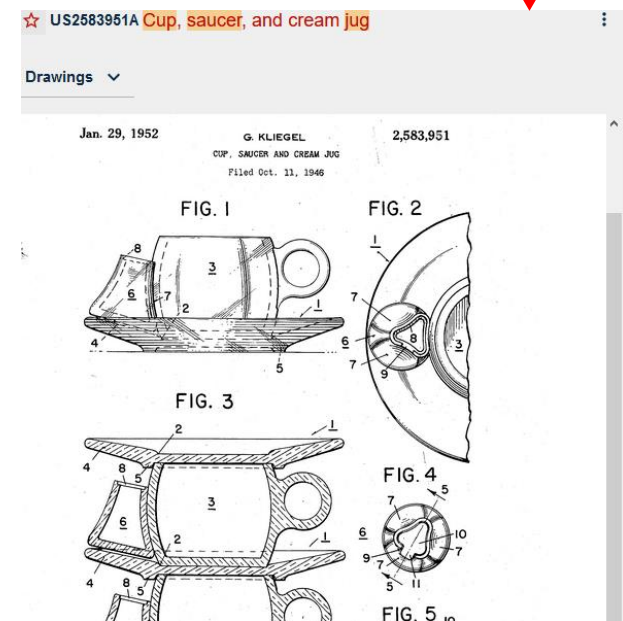

Busca Avançada: Dados Bibliográficos

The screenshot shows the Espacenet patent search interface. At the top, there is a search bar with the query: (ctxt any "jug" OR ctxt any "pitcher") AND ctxt=("cup*" prox/distance<3 "saucer*"). The search results show 12 results found. The first result is highlighted with a red circle and a red arrow pointing to the 'Bibliographic data' tab. The 'Bibliographic data' tab is selected, and the following information is displayed:

- Inventors:** GEORGE KLIEGEL +
- Classifications:**
 - IPC: **A47G19/23;**
 - CPC: **A47G19/04 (EP); A47G19/2283 (EP); A47G19/23 (EP); Y10S215/07 (EP);**
- Priorities:** US70264646A 1946-10-11
- Application:** US70264646A 1946-10-11
- Publication:** US2583951A 1952-01-29
- Published as:** US2583951A

The 'Abstract' section shows: No abstract found. Please consult other publications of this patent family in "Available in", if displayed above.

On the right side of the page, there are technical drawings of the patent. The drawings are labeled FIG. 1, FIG. 2, FIG. 3, and FIG. 4. FIG. 1 shows a perspective view of a cup on a saucer with a cream jug. FIG. 2 shows a side view of the saucer. FIG. 3 shows a perspective view of a stand for the cup and saucer. FIG. 4 shows a top view of the saucer. The drawings are dated Jan. 29, 1952, and the inventor is G. KLIEGEL. The patent number is 2,583,951. The title is 'CUP, SAUCER AND CREAM JUG' and it was filed on Oct. 11, 1946.

Exemplo da Exibição dos **Dados bibliográficos**.

Busca Avançada: Relatório Descritivo

Home > Results > US2583951A

12 results found

List view: Text only | List content: All | Sort by: Relevance

(0 patents selected) Select the first 12 results

- 1. **Cup, saucer, and cream jug**
US2583951A • 1952-01-29 • No applicant available
Earliest priority: 1946-10-11 • Earliest publication: 1952-01-29
No abstract available
- 2. **Cup, saucer, and cream jug** combination
US2618943A • 1952-11-25 • No applicant available
Earliest priority: 1952-01-31 • Earliest publication: 1952-11-25
No abstract available
- 3. **A tea-set stand**
GB850093A • 1960-09-28 • B C JEWERS LTD
Earliest priority: 1957-11-22 • Earliest publication: 1960-09-28
850,093. Stands. JEWERS Ltd., B. C. Feb. 23, 1959 [Nov. 22, 1957], No. 32882/57. Class 52(3) A stand for the display, carrying or storage of a tea-set has a plate ring 10. saucer ring 11 and a cup hook and handle assembly 13 spaced apart vertically and held in position by
- 4. **Central armrest box for car**
CN107264420A • 2017-10-20 • JIANGSU FARID SPECIAL AUTOMOBILI...
Earliest priority: 2017-05-31 • Earliest publication: 2017-10-20
... expansion hinge, two **cup saucers**, a mobile phone slot, hinges, a thermal **jug**, a heating device and a control switch. Storage spaces are installed on the right side of the armrest box body through an expansion hinge, the **cup saucers** are... **jug** is arranged on the lower portion

US2583951A Cup, saucer, and cream jug

Bibliographic data | **Description** | Claims | Drawings | Original document | Citations | Legal events | Patent family

The EPO does not accept responsibility for the accuracy of data originating from authorities other than the EPO, nor does it guarantee that such data is complete, up-to-date or fit for specific purposes.

Patented Jan. 29, 1952 21583,951
UNITED STATES PATENT OFFICE
2,583,951
CUP, SAUCER, AND CREAM JUG
George Kliegel, Washington, D. C.
Application October 11, 1946, Serial No. 702,646 1?. Claims.

It is an object of the present invention to provide for supporting a small cream jug on a saucer in a stable and satisfactory condition while a waiter is serving a cup of coffee, tea or other beverage, and also when cups, saucers and jugs are stacked in sets of assembled cups, saucers and jugs.

It is a further object of the invention to provide a simple and effective closure for the cream jug, which closure may be readily applied to the jug after the latter has been filled with cream, and also to provide for the convenient removal of the closure without requiring the use of a knife, fork or other instrument and without danger of spilling the contents of the jug.

Jan. 29, 1952 G. KLIEGEL 2,583,951
CUP, SAUCER AND CREAM JUG
Filed Oct. 11, 1946

FIG. 1
FIG. 2
FIG. 3
FIG. 4

Exemplo da Exibição do **Relatório Descritivo**.

Busca Avançada: Reivindicações

Espacenet Patent search

(ctxt any "jug" OR ctxt any "pitcher") AND ctxt=("(cup*" prox/distance<3 "saucer*"))

Office/Language

My Espacenet Help Classification search Results Advanced search Filters Popup tips Report data error Feedback

Home > Results > US2583951A

12 results found

List view Text only List content All Sort by Relevance

(0 patents selected) Select the first 12 results

- 1. **Cup, saucer, and cream jug**
US2583951A • 1952-01-29 • No applicant available
Earliest priority: 1946-10-11 • Earliest publication: 1952-01-29
No abstract available
- 2. **Cup, saucer, and cream jug combination**
US2618943A • 1952-11-25 • No applicant available
Earliest priority: 1952-01-31 • Earliest publication: 1952-11-25
No abstract available
- 3. **A tea-set stand**
GB850093A • 1960-09-28 • B C JEWERS LTD
Earliest priority: 1957-11-22 • Earliest publication: 1960-09-28
850,093. Stands. JEWERS Ltd., B. C. Feb. 23, 1959 [Nov. 22, 1957], No. 32882/57. Class 52(3) A stand for the display, carrying or storage of a tea-set has a plate ring 10. saucer ring 11 and a cup hook and handle assembly 13 spaced apart vertically and held in position by
- 4. **Central armrest box for car**
CN107264420A • 2017-10-20 • JIANGSU FARID SPECIAL AUTOMOBILI...
Earliest priority: 2017-05-31 • Earliest publication: 2017-10-20
... expansion hinge, two **cup saucers**, a mobile phone slot, hinges, a thermal **jug**, a heating device and a control switch. Storage spaces are installed on the right side of the armrest box body through an expansion hinge, the **cup saucers** are... **jug** is arranged on the lower portion

☆ US2583951A **Cup, saucer, and cream jug**

Patent Translate

Bibliographic data Description **Claims** Drawings Original document Citations Legal events Patent family

Original claims Claims tree

The EPO does not accept responsibility for the accuracy of data originating from authorities other than the EPO, nor does it guarantee that such data is complete, up-to-date or fit for specific purposes.

What I claim is:

In combination, a saucer having a flat central portion and an annular marginal portion extending outwardly and upwardly therefrom, a cup seated upon said central portion of the saucer, and a flat bottomed **jug** supported upon the upper face of the marginal portion of the saucer and provided with a plurality of side faces extending upwardly from its base, each of said faces having a surface contour conforming to the surface contour of the side wall of the cup, said **jug** resting against the cup with one of its contoured side faces in surface contact with the side wall thereof.

2. In combination, a saucer having a flat central portion and an annular marginal portion extending outwardly and upwardly therefrom, a cup seated upon said central portion of the saucer, and a flat bottomed **jug** supported upon the upper face of the marginal portion of the saucer and provided with a plurality of side faces extending upwardly and inwardly from its base, each of said faces having a surface contour conforming to the surface contour of the side wall of the cup, said **jug** resting against the cup with one of its contoured side faces in surface contact with

Jan. 29, 1952 G. KLIEGEL 2,583,951
CUP, SAUCER AND CREAM JUG
Filed Oct. 11, 1946

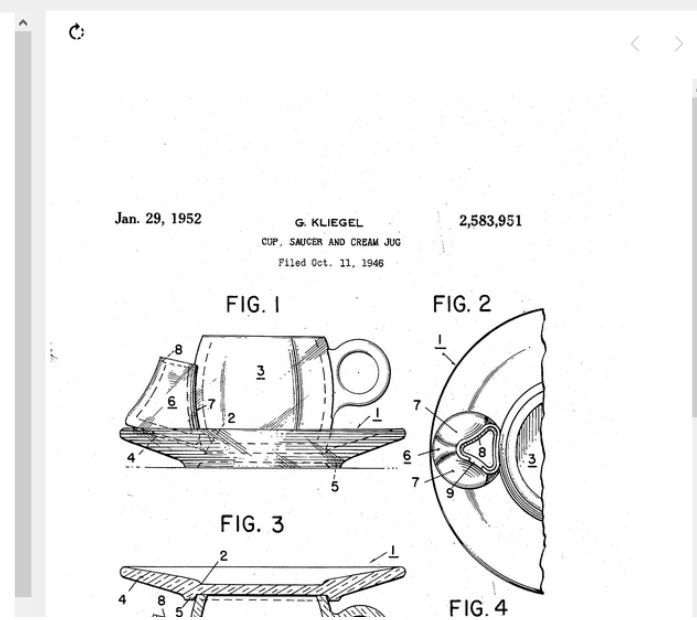

Exemplo da Exibição das **Reivindicações**.

Busca Avançada: Documento Original

Espacenet Patent search

(ctx any "jug" OR ctx any "pitcher") AND ctx=(("cup" prox/distance<3 "saucer"))

Office/Language

My Espacenet Help Classification search Results Advanced search Filters Popup tips [Report data error](#) [Feedback](#)

Home > Results > US2583951A

12 results found

List view Text only List content All Sort by Relevance

(0 patents selected) Select the first 12 results

- 1. **Cup, saucer, and cream jug**
US2583951A • 1952-01-29 • No applicant available
Earliest priority: 1946-10-11 • Earliest publication: 1952-01-29
No abstract available
- 2. **Cup, saucer, and cream jug combination**
US2618943A • 1952-11-25 • No applicant available
Earliest priority: 1952-01-31 • Earliest publication: 1952-11-25
No abstract available
- 3. **A tea-set stand**
GB850093A • 1960-09-28 • B C JEWERS LTD
Earliest priority: 1957-11-22 • Earliest publication: 1960-09-28
850,093. Stands. JEWERS Ltd., B. C. Feb. 23, 1959 [Nov. 22, 1957], No. 32882/57. Class 52(3) A stand for the display, carrying or storage of a tea-set has a plate ring 10. saucer ring 11 and a cup hook and handle assembly 13 spaced apart vertically and held in position by
- 4. **Central armrest box for car**
CN107264420A • 2017-10-20 • JIANGSU FARID SPECIAL AUTOMOBILI...
Earliest priority: 2017-05-31 • Earliest publication: 2017-10-20
... expansion hinge, two **cup saucers**, a mobile phone slot, hinges, a thermal **jug**, a heating device and a control switch. Storage spaces are installed on the right side of the armrest box body through an expansion hinge, the **cup saucers** are... **jug** is arranged on the lower portion

US2583951A Cup, saucer, and cream jug

Bibliographic data Description Claims Drawings Original document Citations Legal events Patent family

Bibliographic data Description Claims Drawings

Page 2 / 3

Patented Jan. 29, 1952 2,583,951

2,583,951
CUP, SAUCER, AND CREAM JUG
George Kliegel, Washington, D. C.
Application October 11, 1946, Serial No. 702,646
2 Claims. (Cl. 65-31)

1 It is an object of the present invention to provide for supporting a small cream jug on a saucer in a stable and satisfactory condition while a waiter is serving a cup of coffee, tea or other beverage, and also when cups, saucers and jugs are stacked in sets of assembled cups, saucers and jugs.

2 It is a further object of the invention to provide a simple and effective closure for the cream jug, which closure may be readily applied to the jug after the latter has been filled with cream, and also to provide for the convenient removal of the closure without requiring the use of a knife, fork or other instrument and without danger of spilling the contents of the jug.

3 With these and other objects in view, the present invention consists in the combination and arrangement of parts, as will be hereinafter more fully described, shown in the drawings and particularly pointed out in the appended claims, it of course being understood that details in the form, proportion, size and minor details may be made, within the scope of the claims, without departing from the spirit or sacrificing any of the advantages of the invention.

4 In the drawing:
Figure 1 is a side elevation of a saucer, cup and

5 top of the cup 3. The upper surface of the saucer of the present invention, from the seat or depression 2 outwardly to the outer periphery of the saucer, as at 4, inclined upwardly and outwardly as best shown in Figure 3 so that its general configuration is that of the frustum of a cone. The bottom of the saucer is provided with a circular rib 8 concentrically disposed and providing a base for the support of the saucer.

6 The circular rib 8 defines a seat or socket of a diameter such that it will snugly receive the top edge of the cup when the saucer is placed thereon as shown in Figure 3, whereby a plurality of saucers, cups and cream jugs may be stacked in units, each unit including a saucer, a cup and a cream jug. When thus stacked, the cups may be empty or they may contain cream.

7 The jug member 6 of the present invention has a comparatively flat bottom face to rest upon the upper surface 4 of the saucer and is tapered inwardly from the base of the jug upwardly so that when the jug is placed upon the top surface 4 of the saucer with the inclined face of the jug lying against the adjacent face of the cup, the center of gravity of the jug is at the cup side of the jug, which puts the jug in a stable position as a result

8 sufficient tightness to normally maintain the cover in place and at the same time permit of the cover being readily removed by manipulation of the finger-piece 11.

9 A very important advantage of the present invention is well shown in Figure 3 of the drawing wherein it will be seen that the seat 2 in the top face of the saucer and the seat defined by the circular rib on the bottom of the saucer are so proportioned that a plurality of units made up of a cup and saucer may be assembled in a vertical stack with a cream jug on each saucer and disposed in a stable condition. When thus stacked, the cups and the jugs may be empty or filled with a liquid, and, in either condition, a waiter may conveniently remove from the top of the stack a unit consisting of a saucer, cup and cream jug without losing time to assemble the three members into a unit.

10 What I claim is:
1. In combination, a saucer having a flat central portion and an annular marginal portion extending outwardly and upwardly therefrom, a cup seated upon said central portion of the saucer, and a flat bottomed jug supported upon the upper face of the marginal portion of the saucer and provided with a plurality of side faces extending upwardly from its base, each of said faces having a surface contour conforming to the surface contour of the side wall of the cup, said jug resting against the cup with one of its contoured side faces in surface contact with the side wall thereof.

11 2. In combination, a saucer having a flat central portion and an annular marginal portion extending outwardly and upwardly therefrom, a cup seated upon said central portion of the saucer, and a flat bottomed jug supported upon the upper face of the marginal portion of the saucer

12 and provided with a plurality of side faces extending upwardly and inwardly from its base, each of said faces having a surface contour conforming to the surface contour of the side wall of the cup, said jug resting against the cup with one of its contoured side faces in surface contact with the side wall thereof.

13 GEORGE KIEGEL.

14 REFERENCES CITED
The following references are of record in the file of this patent:

15 UNITED STATES PATENTS

Number	Name	Date
D. 35,477	Gmichel	Dec. 24, 1941
D. 130,569	O'Brien	Nov. 28, 1944
919,408	Royer	Apr. 27, 1959
1,187,809	Gardian	June 20, 1936
1,350,056	Gregory	Nov. 16, 1920
1,421,096	Kucera	July 4, 1922
1,506,193	Wollen	Aug. 17, 1926
1,665,269	Weaver	Apr. 10, 1928
1,696,389	Mander	Apr. 17, 1928
1,698,992	Smith	Oct. 23, 1928
1,822,808	Dawson	Nov. 17, 1931
1,948,822	McMickle	Feb. 27, 1934
2,012,113	Thompson	Aug. 20, 1935
2,041,563	Meinecke	May 19, 1938
2,097,968	Hale	July 14, 1939
2,121,116	Cope	June 21, 1938
2,121,654	Donchian	June 21, 1933
2,261,720	Sheffs	May 5, 1942
2,314,833	Johns et al.	Mar. 23, 1943
2,348,028	Rasch	May 2, 1944

16 FOREIGN PATENTS

Number	Country	Date
389,646	France	July 4, 1936

Exemplo da Exibição do Documento original.

Busca Avançada:

Outras vantagens da base *Espacenet* é que ela fornece informações sobre:

- a **família de patentes** do documento selecionado na lista de resultados da busca;
- a **situação legal** do documento, em determinada data;
- as **citações** relacionadas ao documento de patente selecionado:
 - documentos **citados** (*cited documents*);
 - documentos **citantes** (*citing documents*).

Busca Avançada: Citações

Exemplo da Exibição das **Citações: Documentos citados.**

The screenshot shows the Espacenet search results for the query: (ctxt any "jug" OR ctxt any "pitcher") AND ctxt=("cup*" prox/distance<3 "saucer**"). The search results page displays 12 results found. The selected document is US2583951A, titled "Cup, saucer, and cream jug". The "Citations" tab is active, showing a list of cited documents. The table below lists the cited documents with their publication and priority dates, titles, and IPC/CPC codes.

Publication	Priority date	Publication date	Applicants	Title	IPC	CPC	Citation origin
US2314835A	1940-12-19	1943-03-23		Bucket	A47J47/18	A47J47/18 (EP)	SEA
US2121118A	1936-02-24	1938-06-21		Beverage container	A47G19/22, B65D81/36	A47G19/2227 (EP), B65D81/365 (EP)	SEA
US2348028A	1942-04-06	1944-05-02		Saucer	A47G19/22	A47G19/2283 (EP)	SEA
US1596133A	1924-12-30	1926-08-17		Attachable tray	A47G19/04	A47G19/04 (EP)	SEA
US2012113A	1933-07-18	1935-08-20		Combined container and drinking vessel	A47G19/22	A47G19/2205 (EP)	SEA
US2041563A	1935-10-12	1936-05-19	MEINECKE & COMPANY	Sanitary tumbler cover and coaster	B65D51/02	B65D51/02 (EP)	SEA
US1359056A	1920-04-15	1920-11-16		Supplemental saucer	A47G19/22	A47G19/2283 (EP)	SEA

Neste exemplo, foram **citados** vários **documentos de patente** pelo documento **selecionado**.

Busca Avançada: Citações

Exemplo da Exibição das **Citações: documentos citantes.**

The screenshot shows the Espacenet search results page for the query: (ctxt any "jug" OR ctxt any "pitcher") AND ctxt=("cup*" prox/distance<3 "saucer*"). The search results are sorted by priority date. The selected document is US2618943A, titled "Cup, saucer, and cream jug". The "Citations" tab is active, showing a list of citing documents. The table below lists the citing documents:

Publication	Earliest priority date	Publication date	Applicants	Title	IPC	CPC	Citation origin
US2613517A	1949-10-07	1952-10-14		Creamer	A47G19/22	A47G19/22 (EP)	SEA
GB2577012A	2017-11-28	2020-03-11	CONTRA VISION LTD [GB]	Beverage making assembly	A47G19/14, A47G19/16, A47G19/23	A47G19/14 (EP,GB), A47G19/16 (EP,GB), A47G19/23 (GB), A47G19/23 (EP)	SEA
US2618943A	1952-01-31	1952-11-25		Cup.	A47G19/22	A47G19/22	SEA

Neste exemplo, o documento selecionado na busca é **citado** por outros documentos de patente posteriores.

Busca Avançada: Situação legal

The screenshot shows the Espacenet patent search interface. At the top, there is a search bar with the query: (ctxt any "jug" OR ctxt any "pitcher") AND ctxt=("cup*" prox/distance<3 "saucer*"). The search results page shows 12 results found. The first result is selected, and its details are shown in a side panel. The side panel has tabs for Bibliographic data, Description, Claims, Drawings, Original document, Citations, Legal events, and Patent family. The 'Legal events' tab is active, and a red arrow points to it. Below the tabs is a table of legal events. The table has columns for Event indicator, Category, Event description, Countries, Event date, Effective date, and Details. The second row of the table is circled in red, showing the event 'D: Search and examination' with the description 'ENTRY INTO FORCE OF REQUEST FOR SUBSTANTIVE EXAMINATION' and the date '2017-11-17'.

Home > Results > CN107264420A

12 results found

List view: Text only | List content: All | Sort by: Priority date

(1 patent selected) Select the first 12 results

1. 金属製洋食器の表面処理方法
JP2020162924A • 2020-10-08 • 株式会社青芳
Earliest priority: 2019-03-29 • Earliest publication: 2020-10-08
【課題】 重厚なグインテージ感を有する金属製洋食器を提供する。【解決手段】 金属製洋食器の基材表面をパレル研磨して、研磨材によって生じる打痕や凹凸痕を基材表面に形成する第1のパレル研磨処理工程と、前記第1のパレル

2. Central armrest box for car
CN107264420A • 2017-10-20 • JIANGSU FARID SPECIAL AUT...
Earliest priority: 2017-05-31 • Earliest publication: 2017-10-20
... expansion hinge, two **cup saucers**, a mobile phone slot, hinges, a thermal **jug**, a heating device and a control switch. Storage spaces are installed on the right side of the armrest box body through an expansion hinge, the **cup saucers**

3. A tray
GB2556345A • 2018-05-30 • REBECCA PARKER [GB]
Earliest priority: 2016-10-26 • Earliest publication: 2018-05-30

☆ CN107264420A Central armrest box for car

Bibliographic data | Description | Claims | Drawings | Original document | Citations | **Legal events** | Patent family

The EPO does not accept responsibility for the accuracy of data originating from authorities other than the EPO, nor does it guarantee that such data is complete, up-to-date or fit for specific purposes.

Event indicator	Category	Event description	Countries	Event date	Effective date	Details
CN PB01	Q: Document publication	PUBLICATION		2017-10-20		
CN SE01	D: Search and examination	ENTRY INTO FORCE OF REQUEST FOR SUBSTANTIVE EXAMINATION		2017-11-17		

Nos documentos de patente com data de depósito mais recente, ao clicar na opção “**legal events**” desta base, é possível visualizar, no quadro abaixo, a situação legal do documento selecionado na busca.

Busca Avançada: Família de Patentes

The screenshot shows the Espacenet search results page for the query "(ctxt any "jug" OR ctxt any "pitcher") AND ctxt=("cup*" prox/distance<3 "saucer*")". The search results list 12 results found, with the first result selected: "1. Cup, saucer, and cream jug" (US2583951A). The detailed view of this patent shows the "Patent family" tab selected, displaying a "Simple family" with "INPADOC family" and "Latest legal events" options. The table below shows one application and one publication for the patent family.

Publication	Application number	Family	Title	Publication date	Applicants	CPC
US2583951A	US70264646A	Simple	Cup, saucer, and cream jug	1952-01-29		Y10S215/07 (EP); A47G19/04 (EP); A47G19/2283 (EP); A47G19/23 (EP)

Neste exemplo, a família é composta por apenas 1 documento de patente.

Ao clicar na opção "**patent family**", é possível visualizar, no quadro abaixo, os documentos da "**família simples**" ou "**INPADOC family**" desta base.

Base Espacenet

My Espacenet



☆ US2583951A Cup, saucer, and cream jug

Bibliographic data

Inventors GEORGE KLIEGEL +

Classifications

IPC A47G19/23;

CPC A47G19/04 (EP); A47G19/2283 (EP); A47G19/23 (EP); Y10S215/07 (EP);

Priorities US70264646A-1946-10-11

Application US70264646A-1946-10-11

Publication US2583951A-1952-01-29

Published as US2583951A

EN

Cup, saucer, and cream jug

Abstract

No abstract found. Please consult other publications of this patent family in "Available in", if displayed above.

Ao selecionar o símbolo "**estrela**" adiciona-se o pedido a uma lista de "**favoritos**" (**My Espacenet**).



Europäisches Patentamt
European Patent Office
Office européen des brevets

Espacenet
Patent search

Enter your search

My Espacenet Help Classification search Results Popup tips

My patents My queries My settings

My Patents > US2583951A

1 result found

List view Text only List content All

1. Cup, saucer, and cream jug
US2583951A • 1952-01-29 • No applicant available
Earliest priority: 1946-10-11 • Earliest publication: 1952-01-29
No abstract available

Outros recursos: Tradução

☆ CN209404315U Combined sleeve cup Patent Translate

Bibliographic data **Description** Claims Drawings Original document Citations Legal events Patent family

The EPO does not accept responsibility for the accuracy of data originating from authorities other than the EPO, nor does it guarantee that such data is complete, up-to-date or fit for specific purposes.

EN ZH

[0001] 技术领域

[0002] 本实用新型涉及水杯和水壶组合使用的套杯，是一种组合式套杯。

[0003] 背景技术

[0004] 水杯是一种人们日常生活中用来盛装液体的容器，通常都采用高度大于宽度的圆柱体造型，以便于手拿起并保留液体的温度，一些水杯的一侧设有便于握持的手柄。水壶也是一种人们日常生活中用来盛装液体的容器，其容量一般大于水杯，因此或称为水壶，其中一些水壶用于水和饮料等冷饮的存取，其一般采用塑料制成。现有，一些水壶与水杯成套销售或使用，此类套件产品以茶具居多，如中国专利文献中披露的申请号201310623116.6，授权公告日2015.06.03，实用新型名称“组合茶具”；该茶具的茶壶体中间有一凹槽，该凹槽的直径略大于茶杯体的直径；茶杯体活动嵌入茶壶体中间的凹槽，叠加的茶杯体和茶壶体形成一体，且叠放高度与茶壶盖平齐。但上述结构较难于塑料水壶和塑料水杯结合的产品中，同时现有同类产品中的塑料水壶和塑料水杯较难结合在一起携带和使用。

[0005] 发明内容

[0006] 为克服上述不足，本实用新型的目的是向本领域提供一种组合式套杯，使其解决现有同类产品水壶和水杯较难成套携带和使用，以及水壶内叠加放置水杯时容易产生摇晃的技术问题。其目的是通过如下技术方案实现的。

CN 209404315 U 说明书附图 1/2 页



Os pedidos podem ser traduzidos de duas formas:

- Por meio do menu “**Patent Translate**”;

OU

- **Selecionando o idioma desejado** na tela de exibição do documento.

Outros recursos: Tradução

☆ CN209404315U Combined sleeve cup Patent Translate

Bibliographic data **Description** Claims Drawings Original document Citations Legal events Patent family

The EPO does not accept responsibility for the accuracy of data originating from authorities other than the EPO, nor does it guarantee that such data is complete, up-to-date or fit for specific purposes.

The wording below is an initial machine translation of the original publication. To apply more advanced translation technology, use Patent Translate.

[0001] Technical field

[0002] The utility model relates to a sleeve cup which is used in combination with a water cup and a kettle, and is a combined sleeve cup.

[0003] Background technique

[0004] A water cup is a container used for liquids in people's daily life. It is usually shaped like a cylinder with a height greater than the width, so that the temperature of the liquid can be taken and retained by hand. Some water cups have a handle on one side for easy grip. Kettles are also containers used to hold liquids in people's daily lives. They are generally larger than cups, so they are called kettles. Some of them are used for the access of cold drinks such as water and beverages. They are usually made of plastic. At present, some kettles and cups are sold or used in sets. Such kits are mostly tea sets, such as the application number 201310623116.6 disclosed in the Chinese patent literature, the authorization announcement date 2015.06.03, the utility model name "combination tea set"; the teapot of the tea set There is a groove in the middle of the body, the diameter of the groove is slightly larger than the diameter of the teacup body; the teacup body is embedded in the groove in the middle of the teapot body, and the superposed teacup body and the

图1

Exemplo do pedido traduzido do chinês para o inglês.

OBS: Para a **tradução de documentos**, é melhor utilizar o **Inglês** como idioma de tradução, podendo o documento ser **traduzido** para o **Português** em uma **outra etapa**.

Outros recursos: Compartilhar, Imprimir, Baixar

The image shows a screenshot of the Espacenet patent page for US2583951A, titled "Cup, saucer, and cream jug". The page displays bibliographic data, including inventors (George Kliegel), classifications (IPC: A47G19/23; CPC: A47G19/04, A47G19/2283, A47G19/23, Y10S215/07), and publication dates. A red menu is overlaid on the right side of the page, with red arrows pointing from the menu icon in the top right of the patent page to the menu items. The menu items are: Download (with a sub-menu), Print, and Share this patent (with a sub-menu). The sub-menu for "Download" includes "Original document", "Print", "Share this patent", "Copy link to clipboard", and "Send link by email". The sub-menu for "Share this patent" includes "Share this patent".

Download

Original document

Print

Share this patent

Share this patent

Copy link to clipboard

Send link by email

Download

Print

Share this patent

EN

Cup, saucer, and cream jug

Abstract

No abstract found. Please consult other publications of this patent family in "Available in", if displayed above.

Por meio deste **menu** pode-se:

- **Baixar o documento em PDF;**
- **Imprimir** o documento; e
- **Compartilhar** o documento.

Outros recursos: *Uso de Filtros*

The screenshot displays the Espacenet patent search interface. The search bar contains the query: (ctxt any "jug" OR ctxt any "pitcher") AND ctxt=!("cup*" prox/distance<3 "saucer*"). The search results page shows 12 results found. The first result is highlighted: 1. Cup, saucer, and cream jug (US2583951A). The interface includes a sidebar with filter options such as Countries (publication), Languages (publication), Publication date (publication), Family, Priority date, IPC main groups, IPC subgroups, CPC main groups, CPC subgroups, CPC assigning offices, Applicants, Inventors, and Publication. The 'Filters' button is highlighted with a red box and a red arrow pointing to the search results. The search results list 12 results found, with the first result being 'Cup, saucer, and cream jug' (US2583951A). The interface includes a sidebar with filter options such as Countries (publication), Languages (publication), Publication date (publication), Family, Priority date, IPC main groups, IPC subgroups, CPC main groups, CPC subgroups, CPC assigning offices, Applicants, Inventors, and Publication. The 'Filters' button is highlighted with a red box and a red arrow pointing to the search results.

12 results found

1. Cup, saucer, and cream jug
US2583951A • 1952-01-29 • No applicant available
Earliest priority: 1946-10-11 • Earliest publication: 1952-01-29
No abstract available

2. Cup, saucer, and cream jug combination
US2618943A • 1952-11-25 • No applicant available
Earliest priority: 1952-01-31 • Earliest publication: 1952-11-25
No abstract available

3. A tea-set stand
GB850093A • 1960-09-28 • B C JEWERS LTD
Earliest priority: 1957-11-22 • Earliest publication: 1960-09-28
850,093. Stands. JEWERS Ltd., B. C. Feb. 23, 1959 [Nov. 22, 1957], No. 32882/57. Class 52(3) A stand for the display, carrying or storage of a tea-set has a plate ring 10, saucer ring 11 and a cup hook and handle assembly 13 spaced apart vertically and held in position by

4. Central armrest box for car
CN107264420A • 2017-10-20 • JIANGSU FARID SPECIAL AUTOMOBILI...
Earliest priority: 2017-05-31 • Earliest publication: 2017-10-20
... expansion hinge, two cup saucers, a mobile phone slot, hinges, a thermal jug, a heating device and a control switch. Storage spaces are installed on the right side of the armrest box body through an expansion hinge, the cup saucers are... jug is arranged on the lower portion

US2583951A Cup, saucer, and cream jug

Drawings

Jan. 29, 1952 G. KLIEGEL 2,583,951
CUP, SAUCER AND CREAM JUG
Filed Oct. 13, 1946

FIG. 1 FIG. 2

FIG. 3 FIG. 4

FIG. 5

Habilitando o “**Filters**”, é possível **filtrar o resultado da busca** por meio de **outros dados**, como países, classificações, etc.

Outros recursos: Gráficos

The screenshot shows the Espacenet Patent search interface. At the top, there is a search bar with the text "(ctxt any \"jug\" O". Below the search bar, there are navigation tabs: "My Espacenet", "Help", "Classification search", "Results", and "Advanced search". The "Results" tab is active. Below the navigation tabs, there is a breadcrumb trail: "Home > Results > US2583951A". There are also buttons for "Family" and "Publication". Below these, there are several filter categories with dropdown menus: "Countries (publication)", "Languages (publication)", "Publication date (publication)", "Family", "Priority date", "IPC main groups", "IPC subgroups", "CPC main groups", "CPC subgroups", "CPC assigning offices", "Applicants", "Inventors", "Publication", and "Inventors - country".

É possível **visualizar gráficos** que mostram os resultados da busca.



Outros recursos: *Buscar a Classificação (CPC)*

The screenshot displays the Espacenet Patent search interface. At the top, there is a search bar with the text "Enter your search terms" and a magnifying glass icon. Below the search bar, there are navigation tabs: "My Espacenet", "Help", "Classification search" (which is highlighted), and "Results".

The "Classification search" section features a search bar with the text "Enter a keyword or a classification symbol" and a "Search" button. To the right of the search bar, there is an "Index" button and a list of classification symbols: A, B, C, D, E, F, G, H, Y. Below the search bar, there are several icons for navigation and filtering, including a left arrow, a right arrow, a refresh icon, a search icon, a "CPC" button, a calendar icon, a "[...]" button, a "2000" button, and a "2000" button with a red border. A red "A" with a right arrow is also visible.

The main content area shows a table with the following columns: "Classification symbol", "Title and description", and "S" (with an information icon). The table lists the following classification symbols and their descriptions:

Classification symbol	Title and description	S
<input type="checkbox"/> A	HUMAN NECESSITIES	S
<input type="checkbox"/> B	PERFORMING OPERATIONS; TRANSPORTING	S ⓘ
<input type="checkbox"/> C	CHEMISTRY; METALLURGY	S ⓘ
<input type="checkbox"/> D	TEXTILES; PAPER	S
<input type="checkbox"/> E	FIXED CONSTRUCTIONS	S
<input type="checkbox"/> F	MECHANICAL ENGINEERING; LIGHTING; HEATING; WEAPONS; BLASTING	S ⓘ
<input type="checkbox"/> G	PHYSICS	S ⓘ
<input type="checkbox"/> H	ELECTRICITY	S ⓘ
<input type="checkbox"/> Y	GENERAL TAGGING OF NEW TECHNOLOGICAL DEVELOPMENTS; GENERAL TAGGING OF CROSS-SECTIONAL TECHNOLOGIES SPANNING OVER SEVERAL SECTIONS OF THE IPC; TECHNICAL SUBJECTS COVERED BY FORMER USPC CROSS-REFERENCE ART COLLECTIONS [XRACs] AND DIGESTS	S ⓘ

On the right side of the interface, there is a sidebar titled "Selected classifications" with a "Find patents" button.

CPC

A versão **Espacenet "beta"** permite **buscar pedidos** pela **classificação de patente**, um recurso importante para se checar a classificação do pedido objeto da busca.

Outros recursos: *Buscar a Classificação (CPC)*

My Espacenet Help Classification search Results

Classification search

Enter a keyword or a classification symbol Search Index A B C D E F G H Y

« A47G11/00 A47G21/00 »

Classification symbol	Title and description
<input checked="" type="checkbox"/> A	HUMAN NECESSITIES
<input checked="" type="checkbox"/> A47	FURNITURE; DOMESTIC ARTICLES OR APPLIANCES; COFFEE MILLS; SPICE MILLS; SUCTION CLEANERS IN GENERAL
<input checked="" type="checkbox"/> A47G	HOUSEHOLD OR TABLE EQUIPMENT (book-ends A47B 5/00 ; knives B26B)
<input checked="" type="checkbox"/> A47G 19/00	Table service
<input checked="" type="checkbox"/> A47G 19/22	• Drinking vessels or saucers used for table service (glass or drinking-vessel underlays A47G 23/03 {; cups as travelling or camp articles A45F 3/16 ; collapsible cups A45F 3/20 ; cups made of plastics B65D 1/265 ; made of paper B65D 3/06 ; measuring cups G01F 9/00);
<input checked="" type="checkbox"/> A47G 19/23	• • of stackable type

Selected classifications

A X

A47G19/00/low X

Clear

Find patents

É possível verificar a **classificação** de um pedido, digitando-se **palavras chave** no **campo de busca**.

Para **consultar a classificação**, basta clicar nos **símbolos**.

O **símbolo da classificação** será exposto à direita na tela, e para **realizar a busca**, basta clicar no botão **“Find patents”**

Obtendo ajuda (*Help*)

Espacenet Patent search

My Espacenet Help Classification search Results Advanced search

Home > Results > EP3305877A1

107 results found

List view List content Sort by

Text only All Relevance

(0 patents selected) Select the first 20 results

1. PROCESS FOR PURIFYING BIODIESEL
EP3305877A1 • 2018-04-11 • PETROLEO BRASILEIRO SA PETROBRAS [BR]
Earliest priority: 2016-10-04 • Earliest publication: 2018-04-05
The present invention describes a process for purifying biodiesel without using a filter aid, in which the biodiesel is...

2. filtro para biodiesel
BRMU8902093U2 • 2011-05-03 • BIOTECHNOS PROJETOS AUTOSUSTENTADOS [BR]
Earliest priority: 2009-09-03 • Earliest publication: 2011-05-03
FILTRO PARA BIODIESEL, que opera com óleo vegetal puro ou já utilizado, sendo a filtragem realizada por um filtro impregnado com resina de troca iônica. O produto compreende: - dois grandes filtros (19 e 20); - uma placa metálica suporte (21), apoiada em pés com regulagem de altura (22); - um conjunto de válvulas...

3. Catalytic cracking process for production of diesel from seeds of oleaginous plants
EP2009079A2 (A3, B1) • 2008-12-31 • PETROLEO BRASILEIRO SA PETROBRAS [BR]
Earliest priority: 2007-06-21 • Earliest publication: 2008-12-21
... charge. The diesel, or biodiesel, oil produced by means of said process is of superior quality...

4. BIODIESEL PURIFICATION METHOD
EP2332903A1 (A4, B1) • 2011-06-15 • PETROLEO BRASILEIRO SA PETROBRAS [BR]
Earliest priority: 2008-09-04 • Earliest publication: 2010-03-11
...The present invention concerns a process for purification of biodiesel obtained from castor seed oil by promoting... of electrostatic separation to biodiesel from castor oil in order to separate the glycerol emulsion then formed, in relatively short spaces of time. ...

5. Process for the production of biodiesel
EP2071016A1 (B1) • 2009-06-17 • PETROLEO BRASILEIRO SA [BR]
Earliest priority: 2007-12-13 • Earliest publication: 2009-06-13
The present invention relates to a process for the production of alkyl esters of carboxylic acids from...

6. método sustentável para recuperação de petróleo
BRPI0605371A • 2008-08-05 • PETROLEO BRASILEIRO SA - PETROBRAS [BR]
Earliest priority: 2006-12-22 • Earliest publication: 2008-06-22

Espacenet - help

Glossary

Applicant
Application
Application number
Bibliographic data
Category
CCD
Citation origin
Citations
Cited documents
Citing documents
Claims
Classifications
Country codes
CPC
C-sets
Description
Drawings
Effective date
European Patent Register
Event date
Event indicator
Filing date
INPADOC family
Inventor
IPC
Kind codes
Legal events

CPC

Cooperative Patent Classification (CPC)

A patent classification system developed in partnership between the USPTO and the EPO. It is an extension of the International Patent Classification (IPC) system which further classifies patent documents into specialised categories and is used by more than 45 patent offices.

More specifically, the CPC consists of:

- all IPC symbols
- a "main trunk" of CPC symbols, plus a Y section for tagging emerging technologies or technologies spanning several sections of the CPC
- a 2000 series of indexing codes for additional information ("breakdown" and "orthogonal" codes)

The CPC is subject to ongoing revision by both offices, and documents are reclassified accordingly. It is designed for efficient searching, an important aspect for users of patent information.

Following the launch of the CPC International project on 24/25 August 2019, Espacenet now displays CPC data. This means that the authorities that have assigned CPC classification symbols are now displayed next to each classification symbol.

CPC symbols will continue to be propagated at family level, which means that every member of the simple patent family will display the same CPC symbols in the bibliographic data view.

Ao clicar no termo, aparece uma breve explicação ao lado: neste caso, sobre a CPC.

Para conhecer melhor a base *Espacenet*, é importante consultar o **"help"**, que possui um **glossário** dos principais termos com **breves explicações**.

Considerações finais

Não esqueça de sempre **consultar a cobertura da base**, no momento da busca, para confirmar se esta base atende o seu **objetivo**.

- Você pode consultar a **cobertura de dados** da base *Espacenet* pelos links [EPO - Bibliographic coverage in Espacenet and OPS](#) (dados bibliográficos) ou [EPO - Full-text coverage in Espacenet and OPS \(full-text\)](#).

Bases de dados (de patentes ou outras) são **dinâmicas**, ou seja, recebem mais documentos de tempos em tempos (a cada semana, mês, etc.).



INPI INSTITUTO
NACIONAL DA
PROPRIEDADE
INDUSTRIAL

diesp@inpi.gov.br

www.gov.br/INPI/pt-br